

# WM-FSM Series

## Vandal Resistant Wall Pack Luminaire Field Selectable Wattage/CCT Wet Location

We reserve the right to revise the design or components of any product without notice.

CATALOG #		TYPE
PROJECT/LOCATION		
APPROVED BY		

### SPECIFICATIONS

- DRIVER — Universal Volt 120/277V electronic driver with 0-10V low voltage dimming (100-30%).
- EMERGENCY — Optional 8W Emergency Battery is available.
- FINISH — Weatherproof polyester powder coated finish.
- HOUSING — Die-cast aluminum, corrosion-resistant housing which conducts heat for optimal thermal management. Housing is fully-sealed which prevents moisture and external elements from contaminating the internal components.
- LENS — UV stabilized polycarbonate prismatic lens design provides optimal light distribution and uniformity.
- LIGHT ENGINE — Energy efficient LED - Field Selectable Wattage / CCT. (50,000hr lifespan)
- OPERATING TEMPERATURE — -40°C to 40°C / -40°F to 104°F.
- MOUNTING — Wall mounts to J-BOX via separate mounting plate.
- PHOTOCELL — Optional 120~277V Photocell is available.
- COMPLIANCE — Built to comply with U.S. and Canadian Safety Standards. UL/cUL Listed for Wet Locations.
- WARRANTY — 5-year Limited Warranty.



### ORDERING INFO

Series	Wattage	CCT	Voltage	Finish	Options

#### ORDERING GUIDE:

#### SERIES

WM-FSM = WM Field Selectable Series

#### WATTAGE

Note: See Chart for Wattage/Lumen Output

SLED = \*Selectable LED Wattage: 30W | 50W | 70W | 90W

#### COLOR TEMPERATURE (CCT)

SCCT = \*Selectable CCT: 3000K / 4000K / 5000K

\*Note: Fixtures will ship from factory at lowest wattage and warmest CCT. It is the installer's responsibility to set the fixture at the desired wattage and CCT for their project.

#### VOLTAGE

UNV = Universal Volt (120-277v) Driver

#### STANDARD FINISH

BZ = Bronze Finish

#### PHOTOCELL OPTION

9328 = Photocell

#### EMERGENCY BATTERY OPTION

EL8W = Integral Emergency LED Battery 8 Watt

- 900 Lumens
- 90 Minute Backup Time
- Operating Temp: 10°C to 40°C / 50°F to 104°F

Setting	System Wattage	CRI	Lumens (3000K)	LPW (3000K)	Lumens (4000K)	LPW (4000K)	Lumens (5000K)	LPW (5000K)
Level 1	90W	80	12,000lm	133 lm/W	12,500lm	139 lm/W	12,200lm	136 lm/W
Level 2	70W	80	9800lm	140 lm/W	10,200lm	145 lm/W	9900lm	142 lm/W
Level 3	50W	80	7500lm	150 lm/W	7800lm	155 lm/W	7600lm	152 lm/W
Level 4	30W	80	4800lm	160 lm/W	5000lm	165 lm/W	4900lm	162 lm/W

### DIMENSIONS

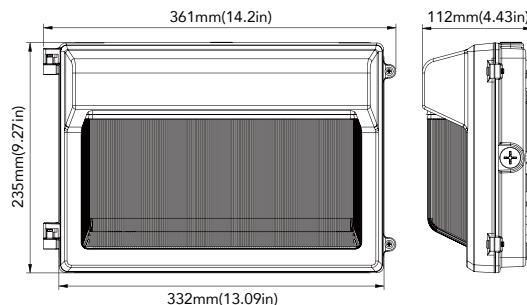

# WM-FSM Series

*Vandal Resistant Wall Pack Luminaire  
Field Selectable Wattage/CCT  
Wet Location*

We reserve the right to revise the design or components of any product without notice.

CATALOG #		TYPE
PROJECT/LOCATION		
APPROVED BY		

## SELECTABLE WATTAGE / CCT CONTROLLER

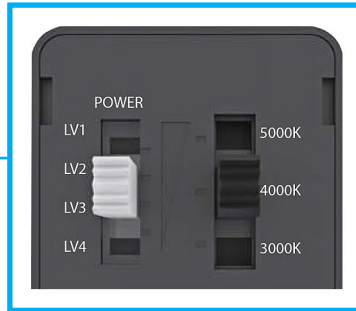

### Selectable Wattage / CCT Controller

Located on the side of the fixture with easy access through the removable screw plug.

Allows the user to make adjustments to the wattage and CCT via the dip switches in the field without a third-party service.

## OPTIONS



### Optional Photocell

Located on top of the fixture with easy access through the removable screw plug.

Allows the user to enable or disable the photocell by adjusting the dipswitch in the field without a third-party service.



### Optional Emergency Battery

8 Watt Emergency Battery provides 900 lumens of light for 90 minutes.