

Sagittarius Pendant

GALILEO PENDANT SERIES

INDOOR/OUTDOOR PENDANT MODEL

Incandescent, Fluorescent, HID, Induction and LED lamp

We reserve the right to revise the design or components of any product without notice.

CATALOG #		TYPE
PROJECT/LOCATION		
APPROVED BY		

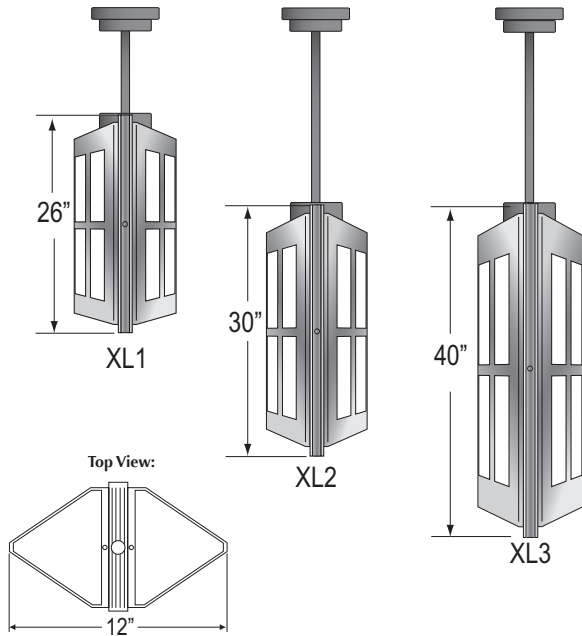

SPECIFICATIONS

- BALLAST** — For Compact Fluorescent Electronic Cold Weather HPF is Standard. For HID Electronic Pulse Start Metal Halide (HPF) is Standard (EBMH).
- DIFFUSER** — White translucent, non-yellowing 100% virgin acrylic, .125 Thick (1/8"). Open top and bottom standard for indoor use; Closed top standard for damp location. Optional Clear or Opaque top and/or bottom.
- FASTENERS** — Stainless steel tamperproof screws (2) to secure lens in place
- FINISH** — Corrosion and Weather resistant, extremely durable pre-treated oven baked polyester powder
- MOUNTING** — Pendant mount. Specify Stem Length.
- PENDANT** — Standard Pendant Model Suspension includes Canopy. Must Specify Stem Length (ST) - 12" is standard length, 24" and custom lengths are optional.
- SHIELD** — Solid Aluminum Opaque Shield. Specify Finish.
- UL/ULC** — UL/ULC Listed to U.S. and Canadian safety standards - Suitable for dry locations. Requires canopy for outdoor installation, damp location.

LAMP TYPE/QTY/WATTAGE ¹				
Fixture Size		XL1	XL2	XL3
Dimensions - W x H x D		12" diameter x 26" length	12" diameter x 30" length	12" diameter x 40" length
Compact Fluorescent Twin Tube	TT	(2)39/40w	(2 or 3)39/40w	(4)39/40w
Compact Fluorescent Double Twin Tube	DTT	(2 or 4)26w	(2 or 4)26w	(4)26w
Compact Fluorescent Triple Twin Tube	TTT	(1)42/57/70w	(2)42/57w; (1)70w	(2)57/70w
Linear Fluorescent	T8	N/A	(3 or 4)17w	(3)17w
Metal Halide: ED17	MH	N/A	(1)50/70w	(1)50/70w; (2)70w
Light Emitting Diode	LED	Consult Factory	Consult Factory	Consult Factory

ORDERING GUIDE:	SERIES	SIZE	LAMP TYPE/QTY/WATT	VOLTAGE/POWER FACTOR	FINISH	OPTIONS

NOTES:

¹ Consult Factory with requests regarding lamp sources, color temp, wattages or voltages not shown.

SERIES

SGP = Sagittarius Pendant

SIZE

- XL1 = 26"
- XL2 = 30"
- XL3 = 40"

STEM LENGTH

- ST12 = 12" Stem Length (1/2" Dia.)
- ST24 = 24" Stem Length (1/2" Dia.)
- STC = Custom Stem Length (72" Max)

LAMP TYPE/LAMP QUANTITY/WATTAGE

Refer to Chart Above

COLOR TEMPERATURE¹ (IND and LED ONLY)

- 3K = 3000K QL; ±3000K range LED
- 4K = 4000K QL; ±4000K range LED
- 5K = 5000K QL; ±4700-5100K LED

VOLTAGE

- 120 = 120 Volts
- 277 = 277 Volts
- 347 = 347 Volts
- EBU = High Temp Universal Volt (120-277v)
Electronic Ballast Programmable Start for CFL

POWER FACTOR

- EB = Electronic Ballast
- 2EB = Two Electronic Ballast
- EBMH = Electronic Ballast for Metal Halide (Standard for ED17 or PARMH)
- IND = Induction HF Generator

FINISH (If model includes PX or SHLD, list second)

STANDARD PAINTED FINISH

- BK = Black
- BZ = Bronze
- PNA = Painted Natural Aluminum
- SGR = Silver Gray
- WH = White

CUSTOM ORDER PAINTED FINISH

- CC = Custom Color (Provide Specs)

LED OPTIONS

- BL = Dual Circuit for Bi-Level Light (High/Low)
- EC1 = (1) Three Watt LED for Emergency Circuit
- EC2 = (2) Three Watt LED for Emergency Circuit
- LDIM = 0-10V low-voltage dimming (100-30% Standard, Consult Factory for Other)
- MS = Motion Sensing ON/OFF with photocell override

OPTIONS

- CLB = Closed Bottom
- CR = Custom Requirements
- CLT = Closed Top — Indoor
- DIM = Dimming Ballast (CFL Only)
- DL = Damp Location — Closed Top (CLT) Included
- FUS = Single Fusing
- DFUS = Double Fusing
- GV = Gravura Custom Engraving (Consult Factory)
- ONTB = Open Top & Bottom (indoor only)
- PX = Alum. Perforated Insert with 1/16" dia. holes (Must Specify Finish)
- TB = Closed Translucent Bottom

CFL EMERGENCY OPTIONS

- REL1 = Remote Emergency Battery T8; 1 Lamp - 600 Lumens
- REL2 = Remote Emergency Battery: DTT/TTT; 1-2 Lamp; 650 Lumens
- REL7 = Remote Emergency Battery: T8/DTT/TTT; 1-2 Lamp; 1400 Lumens