

# Hockey Puck

Pendant Series, Indoor Indirect

We reserve the right to revise the design or components of any product without notice.

CATALOG #		TYPE
PROJECT/LOCATION		
APPROVED BY		

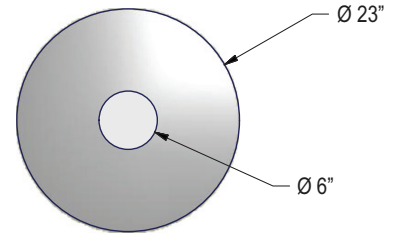
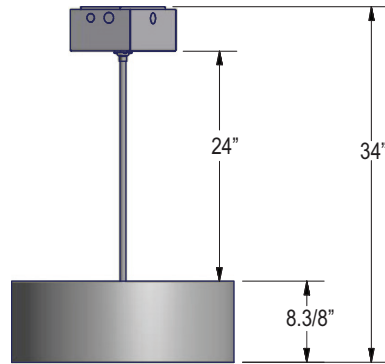

**NOTES**

1) DRAWING IS TO BE USED FOR REFERENCE/QUOTING ONLY. DIMENSIONS ARE SUBJECT TO CHANGE.

**ORDERING GUIDE:**

Series	Style	Lamp Type/Qty/Watt	Voltage: Primary/Emergency	Finish	Options
<input type="text"/>	<input type="text"/>	<input type="text"/>	<input type="text"/>	<input type="text"/>	<input type="text"/>

**SERIES**

**HP** = Hockey Puck Series

**WATTAGE**

**LED170** = 170 Watt LED, 19200 Initial Lumens

**VOLTAGE**

**2EBU** = Two (2) Universal Volt Drivers (120~277V)

**FINISH**

**WH** = White—Standard

**BK** = Black

**BZ** = Bronze

**PNA** = Painted Natural Aluminum

**SGR** = Silver Gray

**OPTIONS**

**PEND24** = Pendant Series, 24" Stem Standard; other lengths available

**D7** = 0-10V low-voltage dimming (100-30% Standard, Consult Factory for Other)

Test Date: 08/10/2015

Tested in accordance with LM-79-80  
The results contained in this summary report pertain only to the tested sample

Electrical Characteristics	120.0V	1.4125A	168.91W
Luminous Efficacy (Lumens/Watts)	66.5		

Summary of Results	
Total Lumen Output	11240
Efficacy (Lm/W)	66.5
CRI	82.93
CCT	4022K
Duv	0.0002

Zonal Lumen Summary		
Zone	Lumens	% Luminaire
0-30	98	.9
0-40	159	1.4
0-60	237	2.1
0-90	296	2.6
90-120	1925	17.1
90-130	3899	34.7
90-150	8314	74.0
90-180	10944	97.4
0-180	11240	100.0

Chromaticity Coordinates	
Chromaticity (x)	0.3800
Chromaticity (y)	0.3785
Chromaticity (u)	0.2241
Chromaticity (v)	0.3349

