

Belgrade

ARCHITECTURAL SERIES

Surface Mount Shallow;
Vandal Resistant HID, CFL

We reserve the right to revise the design or components of any product without notice.

CATALOG #		TYPE
PROJECT/LOCATION		
APPROVED BY		



SPECIFICATIONS

- REFLECTOR — .032 aluminum For High Efficiency
- DIFFUSER — Injection molded 1/8" thick (Norm.) Clear Prismatic completely enclosed fixture. Smooth Outside Standard with Painted Eyelid and Decorative Vertical Bar.
- FASTENERS — (4) Stainless steel tamperproof Torx screws to secure lens to backplate.
- FINISH — Extremely durable five stage oven baked Polyester Powder coat—Color as req'd
- GASKETING — One Piece Die Cut 3/16" Thick Black EPDM and/or neoprene rubber
- HOUSING — Cast aluminum. Specify SC (Shallow Cast) or D (Deep Cast) after Series designator. Optional non-corrosive injection-molded polycarbonate.
- LAMP — Double Twin Tube or Triple Twin Tube mini-fluorescent as required; Metal Halide (Deep Diffuser required)—by others
- MOUNTING HOLES—(4) 5/16" Diameter Holes for 1/4" Diameter Bolts
- UL/ULC Listed to U.S. and Canadian safety standards - Suitable for wet locations.

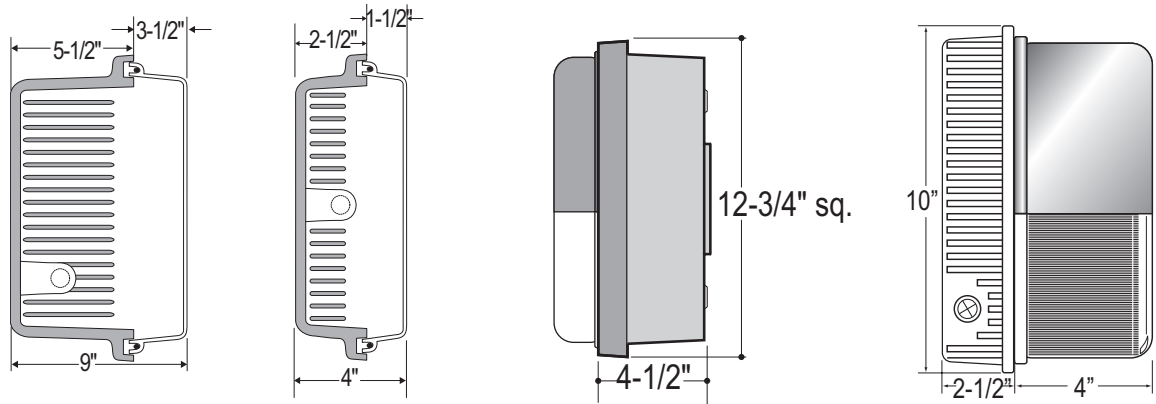

LAMP TYPE/QTY/WATTAGE ①				
Fixture		BELGRADE Shallow Cast	BELGRADE Deep Cast	BELGRADE Large, Deep Cast
Dimensions - W x H x D		11" x 11" x 4"	11" x 11" x 9"	12" x 12" x 9"
Compact Fluorescent Double Twin Tube	DTT	(1 or 2)13/18/26w	(1 or 2)13/18/26w	(1 or 2)13/18/26w
Compact Fluorescent Triple Twin Tube	TTT	N/A	(1 or 2)32w; (1)42w	(1 or 2)32w; (1)42w
Metal Halide 18	MH	50w (DD req'd)	50w (DD req'd)	50w (DD req'd)
Light Emitting Diode	LED	20w	20w	20w

ORDERING GUIDE:	SERIES	SIZE	LAMP TYPE/QTY/WATT	VOLTAGE/POWER FACTOR	FINISH	OPTIONS

NOTES:

- Consult Factory with requests regarding lamp sources, wattages or voltages not shown.
- Deep Diffuser (DD) Required for MH

SERIES

- BL-SC = Belgrade Shallow Casting Series
- BL-D = Belgrade Deep Casting Series
- BL-SC = Belgrade Large Deep Casting Series

LAMP TYPE/QUANTITY/WATTAGE Refer to Chart Above

COLOR TEMP (LED)

- 3K = ±3000K range LED
- 4K = ±4000K range LED
- 5K = ±5000K range LED
- 6K = ±6000K range LED

VOLTAGE

- 120 = 120 Volts
- 277 = 277 Volts
- 347 = 347 Volts
- EBU = Universal Volt (120-277v)
- EB = High Power Factor Electronic Ballast

FINISH

- BK = Black
- BZ = Bronze Standard
- WH = White

OPTIONS

- 5410 = 5410 Backbox - 4-1/2" deep
- 9002 = Torx Tamperproof Screwdriver
- 9206 = Photocell — 120v
- 9221 = Photocell — 277v
- BB = Aluminum Surface Conduit Box
- CPR = Clear Prismatic (prisms inside)
- DD = 4" Deep Diffuser 18
- EL = Any Emergency Battery for CFL: See EL Chart immediately after Architectural/Euro Tab
- FUS = Single Fusing: HLR Fuse and Fuse Holder
- DFUS = Double Fusing
- OPL = Opal Polycarbonate Lens (consult factory)
- SR = Semi Recessed